

NEW DATE OF MANUFACTURE

Workshop:
EP, EL, NB
05.1998
SI 0617 En

With immediate effect, new K-sector products are being given a non-encoded date of manufacture (FD).

The following alternatives are envisaged:

1. Daily date of manufacture

This consists of the respective two-digit number for year, month and day, e.g.:

98 - 04 - 29 for 29.04.1998.

The daily date of manufacture may also be supplemented (in a second line) by the shift code, e.g.

98 - 04 - 29 for 29.04.1998 plus 1000 for 1st shift on 29.04.1998, with no additional information.

Additional information may be given in digits 2 to 4 after the shift code, e.g.:

1342 = 1st shift with additional data on production line and other internal details.

2. Quarterly date of manufacture

This consists of the respective two-digit number for the year and the first month in the quarter, e.g.:
98 - 04 for the second quarter of 1998.

Products released before March 1998 which are still in series production will still be marked with the date of manufacture using the old encoded method, however until the end of 2007 at the latest.

Published by:

Robert Bosch GmbH
Division KH
After-Sales-Service Department for
Training and Technology (KH/VSK)

Please direct questions and comments concerning the contents to our authorized representative in your country.

Nowadays the main aim when developing new alternators is to reduce flow and magnetic noise whilst simultaneously increasing power output.

The liquid-cooled NF alternator represents a completely new approach in this respect.

Main advantages of NF alternator (examples):

- * **Significant noise reduction:** The fully encapsulated design and the absence of fan impellers lead to a reduction of up to 20 dB(A) in alternator noise, particularly in the upper speed range.
- * **Improved current supply:** On account of the insensitivity to high engine temperatures, the current supply in the low speed range in particular is up to 15 A higher than for the air-cooled version with the same characteristic data.

- * Higher power output: Design-related potential (acoustics) for further increase in alternator power.
- * Increased service life: The brushless design results in a longer service life.
- * Shorter engine warm-up time: The power loss of the alternator is supplied to the coolant in the form of heat, thus permitting a reduction in the critical engine warm-up time as a function of alternator load.

- * Less sensitive to radiant heat: As the electrical connections are on the drive end, the alternator is better equipped for fitting in the vicinity of the exhaust or catalytic converter.
- * Fording capability / greater flexibility as regards attachment: By virtue of its encapsulated, water-proof design, the alternator features fording capability and thus permits more flexible attachment.
- * Shorter overall length.

Special features of the NF alternator:

- * **Liquid-cooled:** The alternator is integrated into a corresponding recess in the engine block or into a separate add-on housing
- * **Brushless:** Fixed excitation winding and windingless rotor
- * **Electrical connections on drive end**

- * **Multifunction regulator BRF**
 - Load-response start (no current supplied on and immediately after starting)
 - Load-response operation (delayed increase in power output by way of ramp function)
 - Fault indication via charge warning lamp (V-belt snapped, excitation interrupted, overvoltage)
 - DF monitor (information on current alternator capacity utilisation)
- * **No excitation diodes, i.e. excitation is clocked by regulator via battery positive (B+)**

Alternator NF 90/150A

- 1 = Pulley
- 2 = Multifunction regulator BRF
- 3 = Cap
- 4 = Drive-end shield with rectifier unit
- 5 = Sealing ring
- 6 = Housing (with circulating coolant)
- 7 = Windingless rotor
- 8 = Conductive element
- 9 = Pole body with fixed excitation winding
- 10 = Stator winding (shrink-fit in housing)

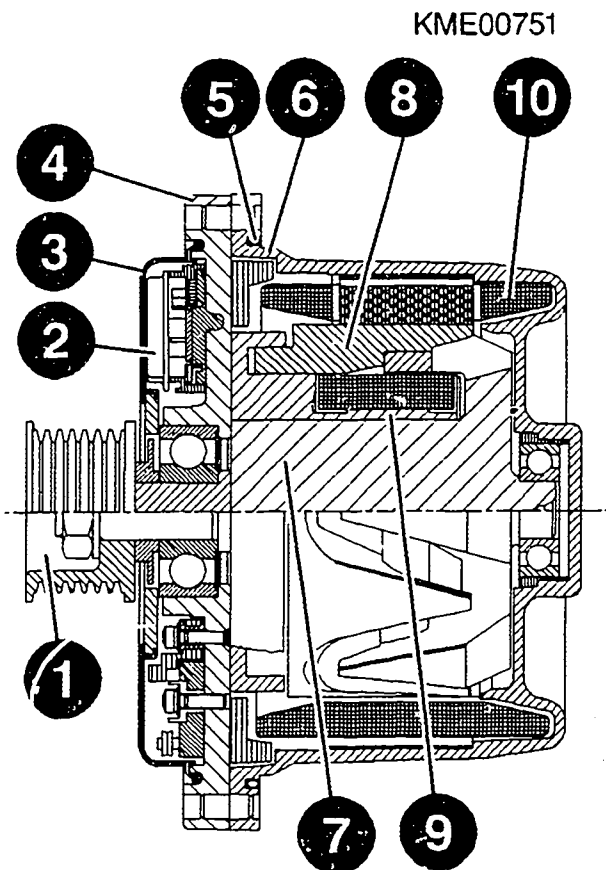

Circuit diagram of alternator NF 90/150A

1 = Alternator

2 = Multifunction regulator BRF

Pin assignment for BMW:

2.1 = Regulator connector pin 1:
terminal 15
(lamp actuation)

2.2 = Regulator connector pin 2:
terminal L
(lamp actuation)

Pin assignment for Mercedes-Benz:

2.1 = Regulator connector pin 1:
terminal L
(lamp actuation)

2.2 = Regulator connector pin 2:
DF monitor (DFM, alternator
capacity utilisation)

KME00494

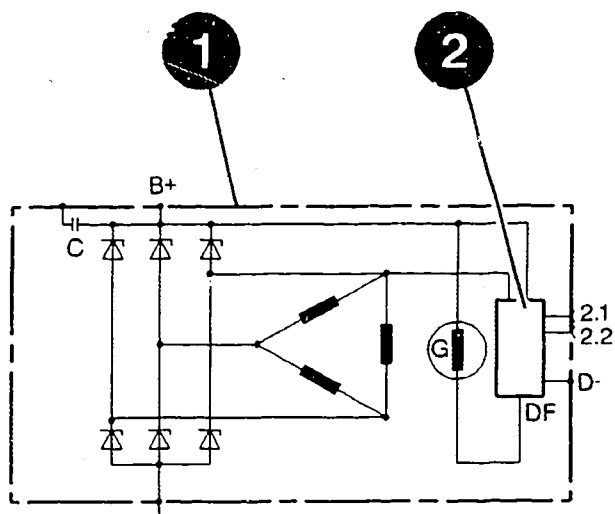

The NF alternator was fitted for the first time as of 6/98 in the BMW 540i (E 39) and 740i (E 38) with engine M62 (8-cyl.).

Repair instructions for the NF alternator were published in 2.99 on the microcard W-001/043.

If complaints are received during the warranty period, the alternator is to be sent unopened together with warranty form G20, G21 to K9/QSG.

Published by:

Robert Bosch GmbH
Division KH
After-Sales-Service Department for
Training and Technology (KH/VSK)

Please direct questions and comments concerning the contents to our authorized representative in your country.